



Atoc Inc.
3615 132nd St SW, Ste C
Lynnwood, WA 98087

(425) 745-2131
www.Atoc.com



INTERCONNECT

Int125 Int200 Int200XL

Assembly and Operation

Int125: fits 1.25 inch receivers

Int200: fits 2 inch receivers

Int200XL: fits 2 inch receivers
(extra long connection arm)

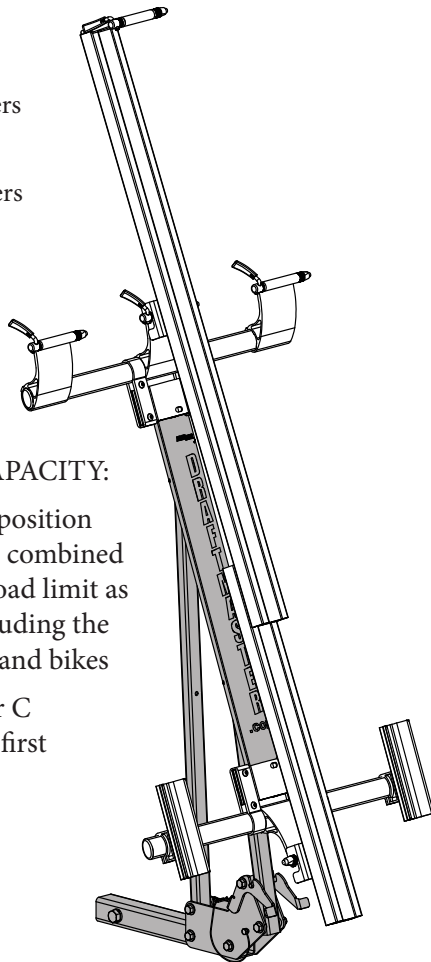

MAXIMUM WEIGHT CAPACITY:

- A) 50 lbs (22.75 kg) per bike position
- B) 150 lbs (68.25 kg) all bikes combined
- C) ½ your receiver's tongue load limit as rated for your vehicle, including the weight of the Draftmaster and bikes

Your limit is A, B, or C
whichever is reached first

NOTE:

Clear parts are shown for
reference and are provided
with other modules

WHAT YOU GET

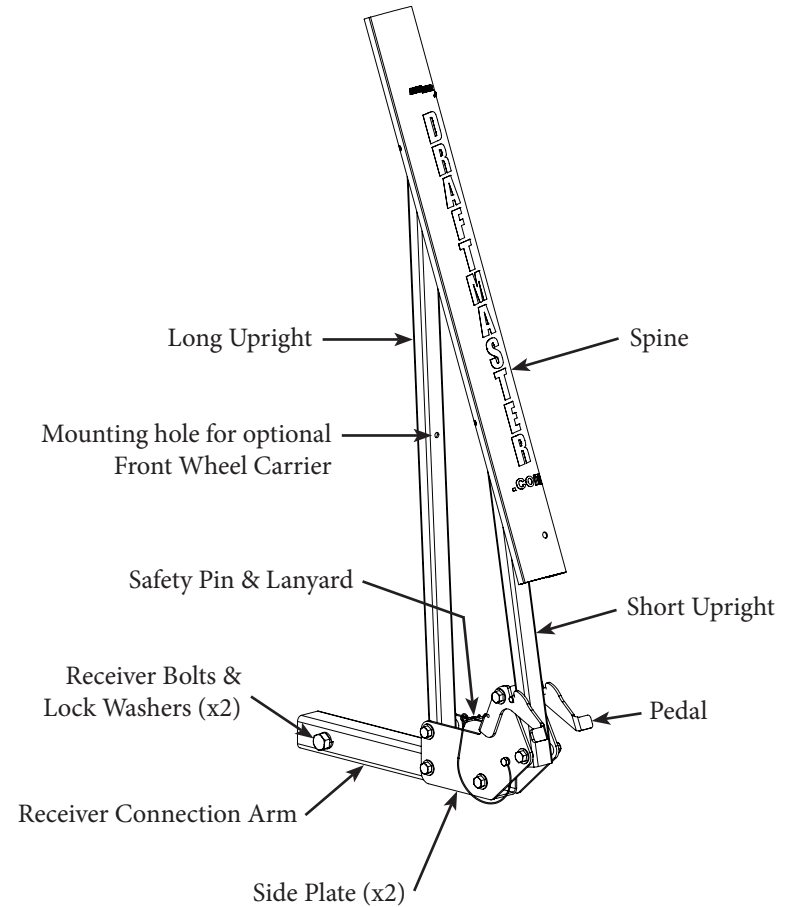

Receiver Connection Arm Options

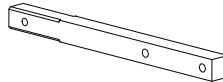
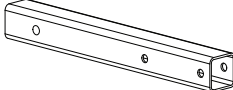
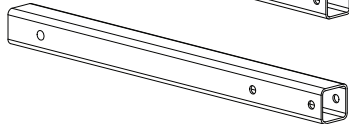
-  **RCA125:** Included with Int125.
Fits 1.25 inch receivers.
-  **RCA200:** Included with Int200.
Fits 2 inch receivers.
-  **RCA200XL (extra long arm):** Included with Int200XL
Fits 2 inch receivers.

TOOLS NEEDED

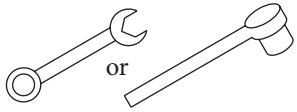

5/8 inch wrench x2

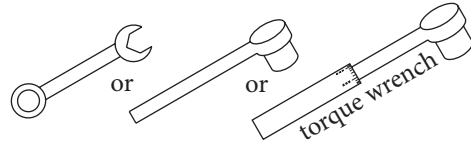

3/4 inch wrench for Int125

15/16 inch wrench for Int200 & Int200XL

Note: The Security Hitch Bolt accessories SHB125 & SHB200 require a 7/8 inch wrench.

ADDITIONAL ITEMS NEEDED

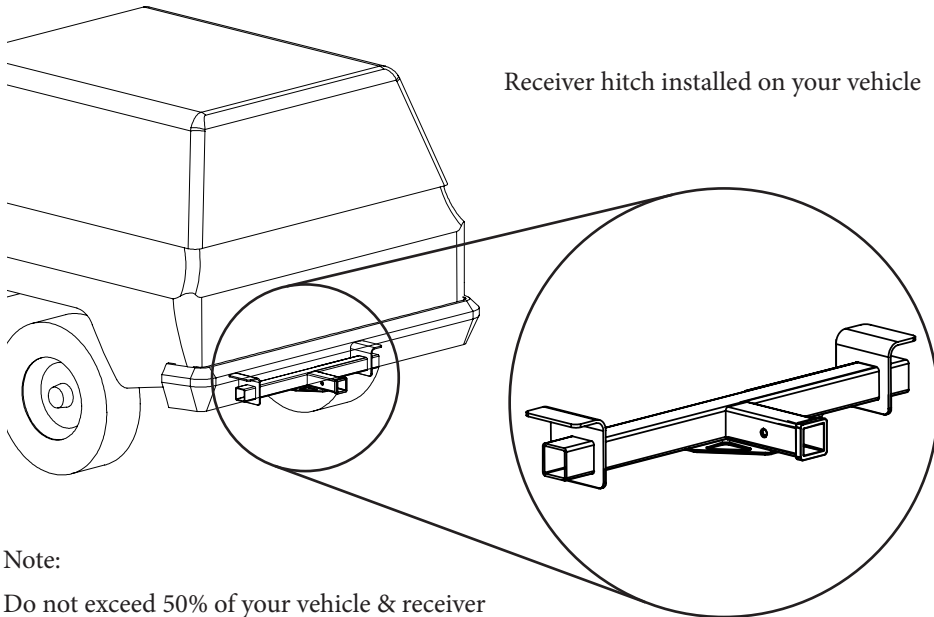

Receiver hitch installed on your vehicle

Note:

Do not exceed 50% of your vehicle & receiver combination's tongue load capacity, including the weight of your Draftmaster and bicycles.

Your vehicle & receiver capabilities may limit your carrying capacity.

ASSEMBLY

Step 1:

Unfold Interconnect as shown.

Remove both receiver bolts and lock washers from the Receiver Connection Arm.

Remove bolt, washers, and nut from lower end of Short Upright.

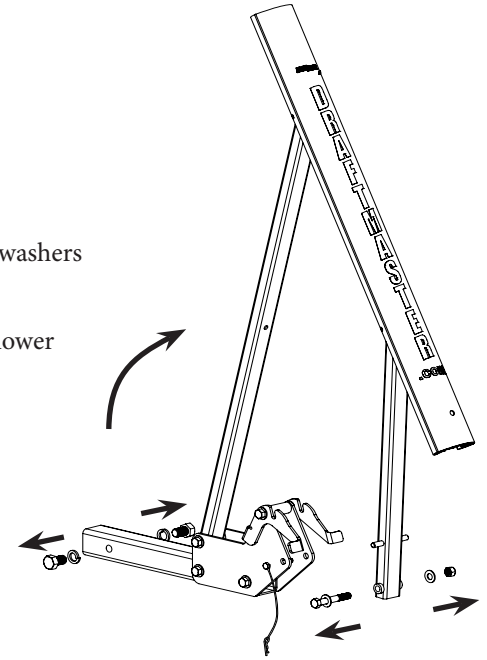

Step 2:

Insert Interconnect into receiver.

Line up bolt holes and loosely install receiver bolts & lock washers on both sides of receiver.

Wiggling the Interconnect in the receiver may help to line up the bolt holes.

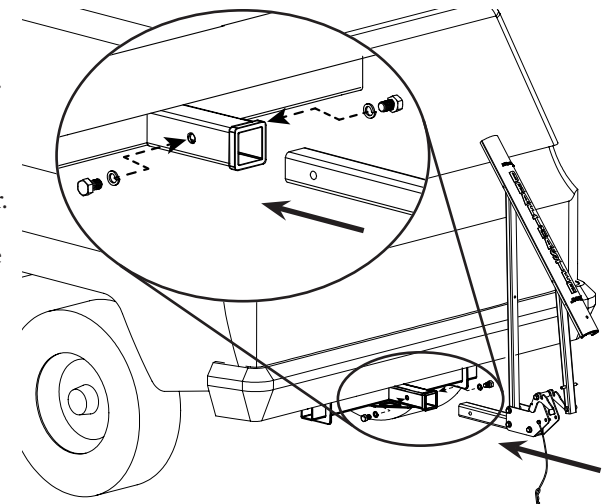

Step 3:

Lower the Spine and align bolt hole at lower end of Short Upright with holes in Side Plates.

Reinstall the bolt, washers, and nut removed in Step 1.

Tighten the nut.
The nut should be tight enough to eliminate wiggle, but loose enough to allow the Short Upright to rotate.

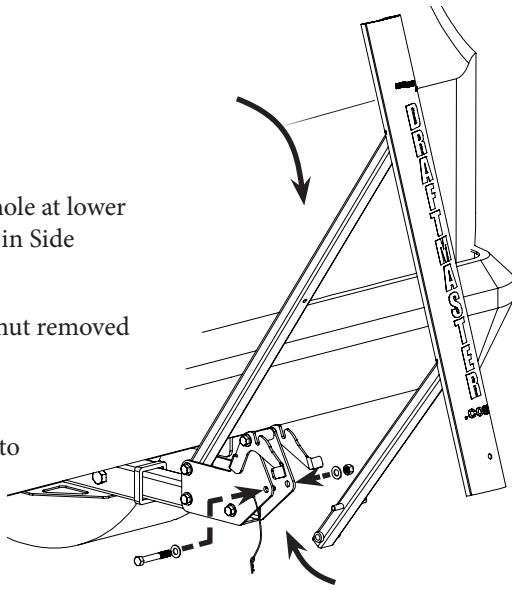

Step 4:

A. Push forward and up on Spine until the peg on the Short Upright latches into the Pedal.

B. Insert Safety Pin thru holes in Pedal & Side Plate.

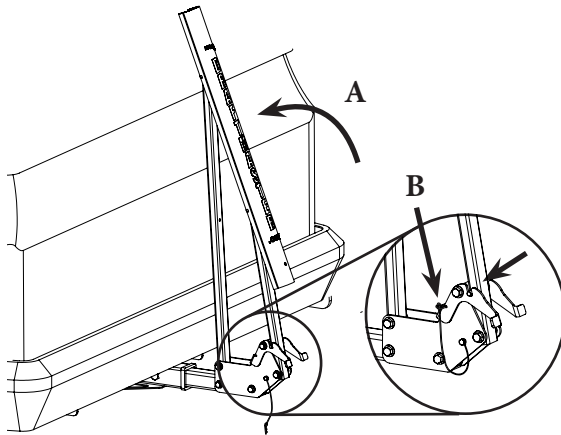

Step 5:

Tighten both receiver bolts to 20 ft-lbs.

Reference:
20 ft-lbs is a 20 lb force applied to a 1 ft wrench.
A gallon of water weights 8 lbs.
2½ gallons weighs 20 lbs.

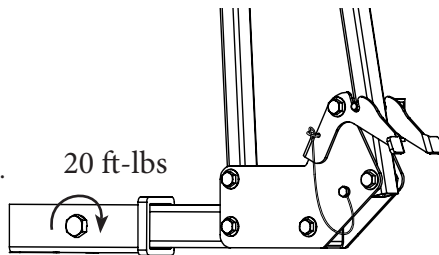

Step 6:

Lower and raise the parallelogram several times to make sure the Interconnect works smoothly and does not wiggle. Adjust as needed as described under Maintenance.

OPERATION

Lower the Interconnect for loading, unloading and vehicle access

A. Remove Safety Pin.

B. Press the Pedal with your foot to release the parallelogram.

C. Pull back on spine.

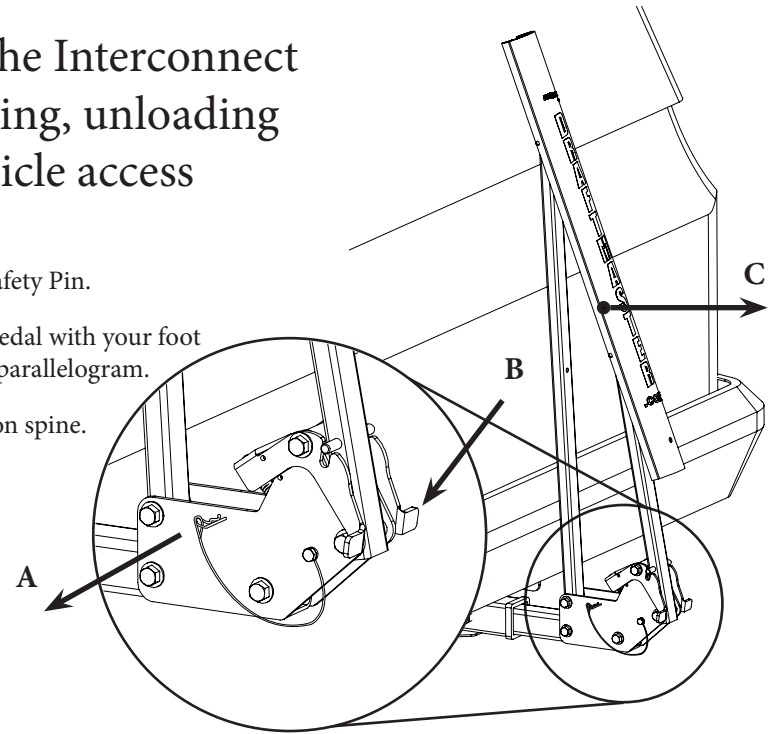

Raise the Interconnect for travel

A. Push forward and up on Spine until the peg on the Short Upright latches into the Pedal.

B. Insert Safety Pin thru holes in Pedal & Side Plate.

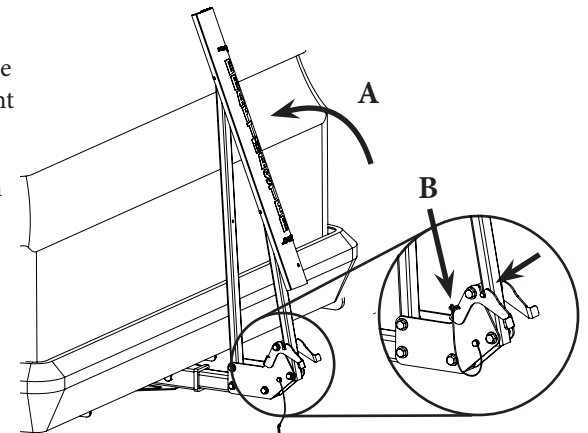

MAINTENANCE

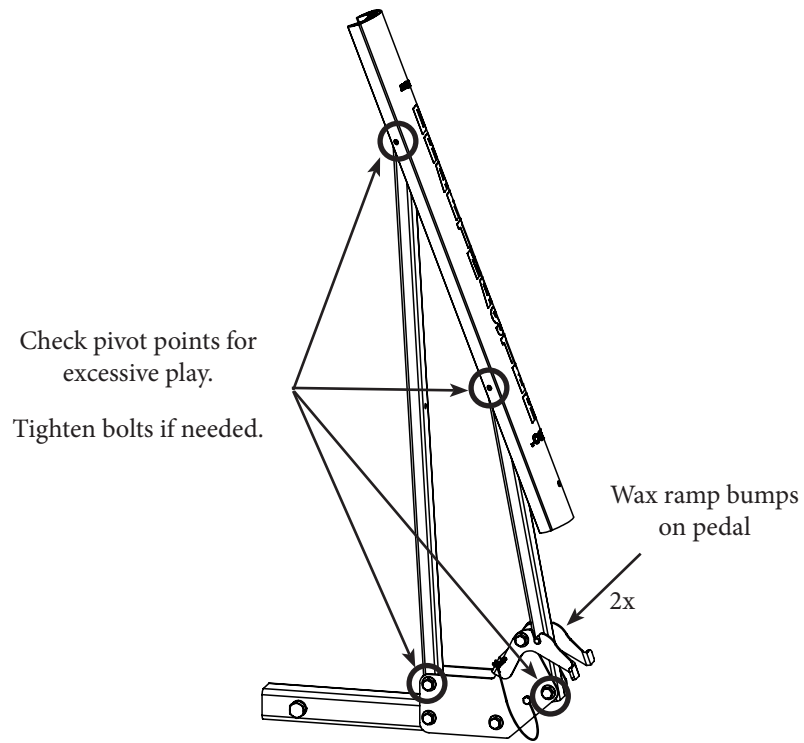

See companion module manuals
for additional instructions as applicable.

WARRANTY

Since Atoc Inc. has no control over the attachment of its products to any vehicle, Atoc Inc. cannot assume responsibility for the attachment or use of its products to any vehicle, nor can Atoc Inc. assume responsibility for any damages resulting from the attachment or use of its products to any vehicle. Atoc Inc. assumes responsibility only for products produced by or for Atoc Inc. The liability of Atoc Inc. is limited to the replacement or repair of merchandise which proves defective in materials and/or workmanship. This liability is further limited to one year from date of purchase. Additionally, any warranty from Atoc Inc. is applicable only if instructions are followed and the product is properly used. Normal wear and tear of merchandise or damage resulting from misuse, accidents, or alterations are not covered by this warranty. If an article is thought to be defective, the customer shall return it to an authorized Atoc Inc. dealer with proof of purchase. Atoc Inc. will then issue authorization to the dealer for the return of these articles. (Alternately, the customer may request to return the article directly to Atoc Inc. if there is not a local Atoc Inc. dealer. Such returns must be authorized in advance by Atoc Inc.) If an article is found to be defective upon inspection by Atoc Inc., Atoc Inc. will repair or replace the article at its discretion without charge. Freight is not included. Unauthorized returns will not be accepted.